

FANLAB

PRODUCT SPECIFICATION

Customer: _____

Name : _____

Model: FL-EC500V-T400S13760-B1 _____

Version: V2 _____

Edit: _____

Auditing: _____

Approval: _____

2023-07-14

FANLAB

General

This specification defines the general data, mechanical, electrical characteristics, environment and experiment, performance curve, Outline Drawing and precautions of the EC external rotor axial fan and so on.

Standard:

GB 12350-2009 《Safety requirements of small power motors》

GB/T 21418-2008 《General specification for permanent magnet brushless motor system》

JB/T 10562-2006 《Technical specification for general purposes axial fans》

General Data

No.	Name	Parameter
2.1	Max Air Flow	9700m ³ /h
2.2	Rated Speed	1600 r/min
2.3	Input Power	940W
2.4	Rated Voltage	400V
2.5	Operating Voltage	380-480 VAC
2.6	Start Voltage	≤304VAC
2.7	Rated Current	≤1.8A
2.8	Noise Level	75±5dB(A)
2.9	Direction	CCW(seen on rotor of motor)
2.10	Insulation Class	F
2.11	Speed Control	0~10VDC & PWM
2.12	Grounding Resistance	≤0.1 Ω
2.13	Withstand voltage	Voltage:2500VDC Tripping current:10mA Time: 60 s
2.14	Insulation Resistance	Voltage:500VDC Resistance: ≥50M Ω

FANLAB

No.	Name	Parameter
2.15	Electrical Protection	Undervoltage protection Overvoltage protection Overcurrent protection Locked rotor protection Automatic restart capability Soft start
2.16	IP Class	IP54
2.17	Signal Feedback	FG sign:open-drain output, 1 pulses/R
2.18	Voltage output	+10VDC
2.19	RoHS	All the material meets RoHS standard.
2.20	Color(Impeller and mounting frame)	Black
2.21	Bearing	Deep groove ball bearings
2.22	Weight	17.8Kg
2.23	Package	Carton+ pallet
2.24	Operating Temperature	-40°C to 60°C
2.25	Operating Humidity	5% to 90% RH
2.26	Lead Wire	RV 90 4*0.75mm ² L=1.5m
2.27	Control Wire	RV 90 4*0.5mm ² L=1.5m

FANLAB

Performance curve and Rating plate

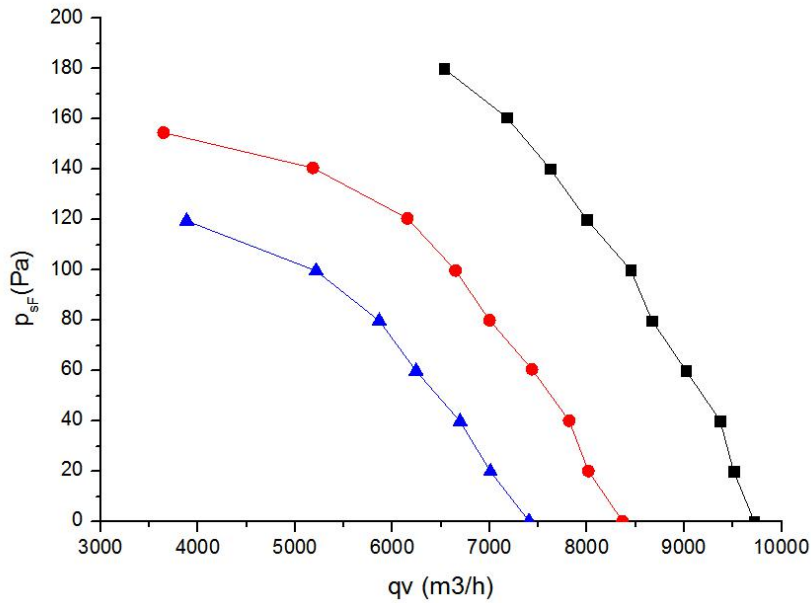

FANLAB FL-EC500V-T400S13760-B1

400V 50/60Hz 780/940W 1600r/min CL.F IP54

Erp2015(N40) N=41.2 $\eta_{statA}=34.7\%$

Blk: L1 Bro:L2 Blu:L3 Yel-Gre:PE

Red:+10V Blu:GND Whi:Tach output Yel:0~10VDC/PWM

CE

Outline Drawing

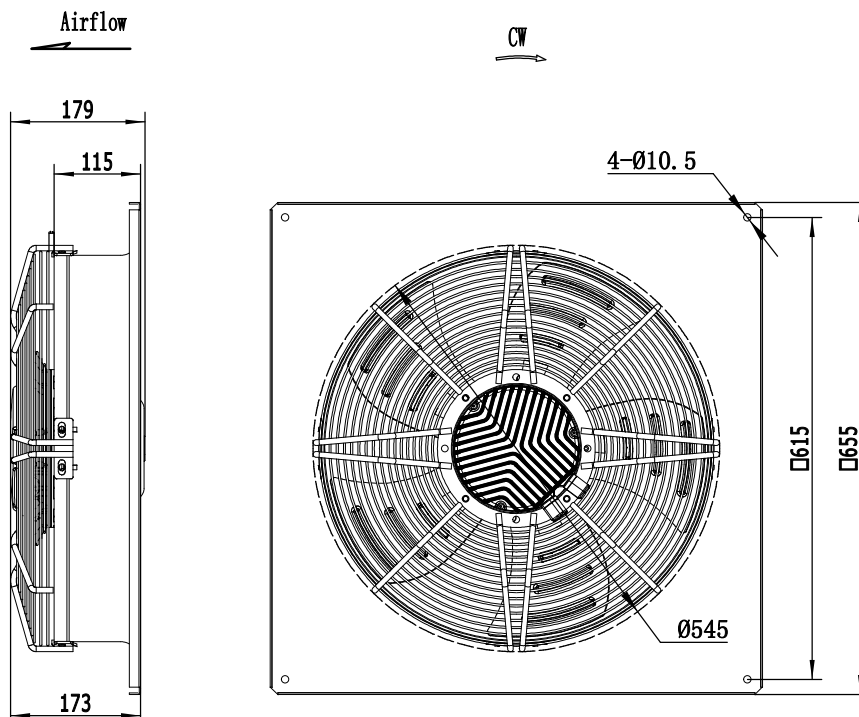

FANLAB

Connection Diagram

(1). Motor connection diagram:

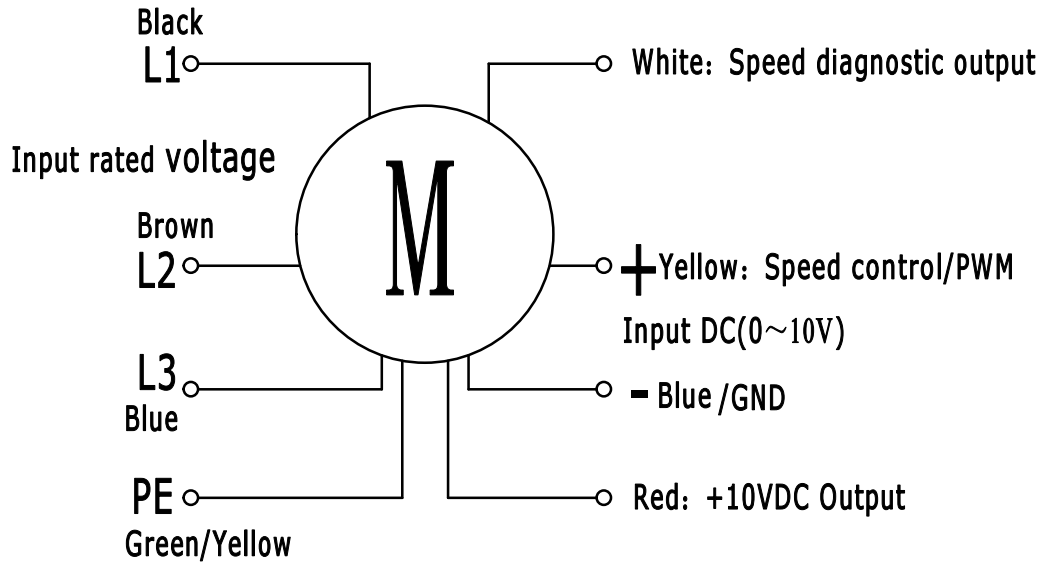

(2). Interface Circuit:

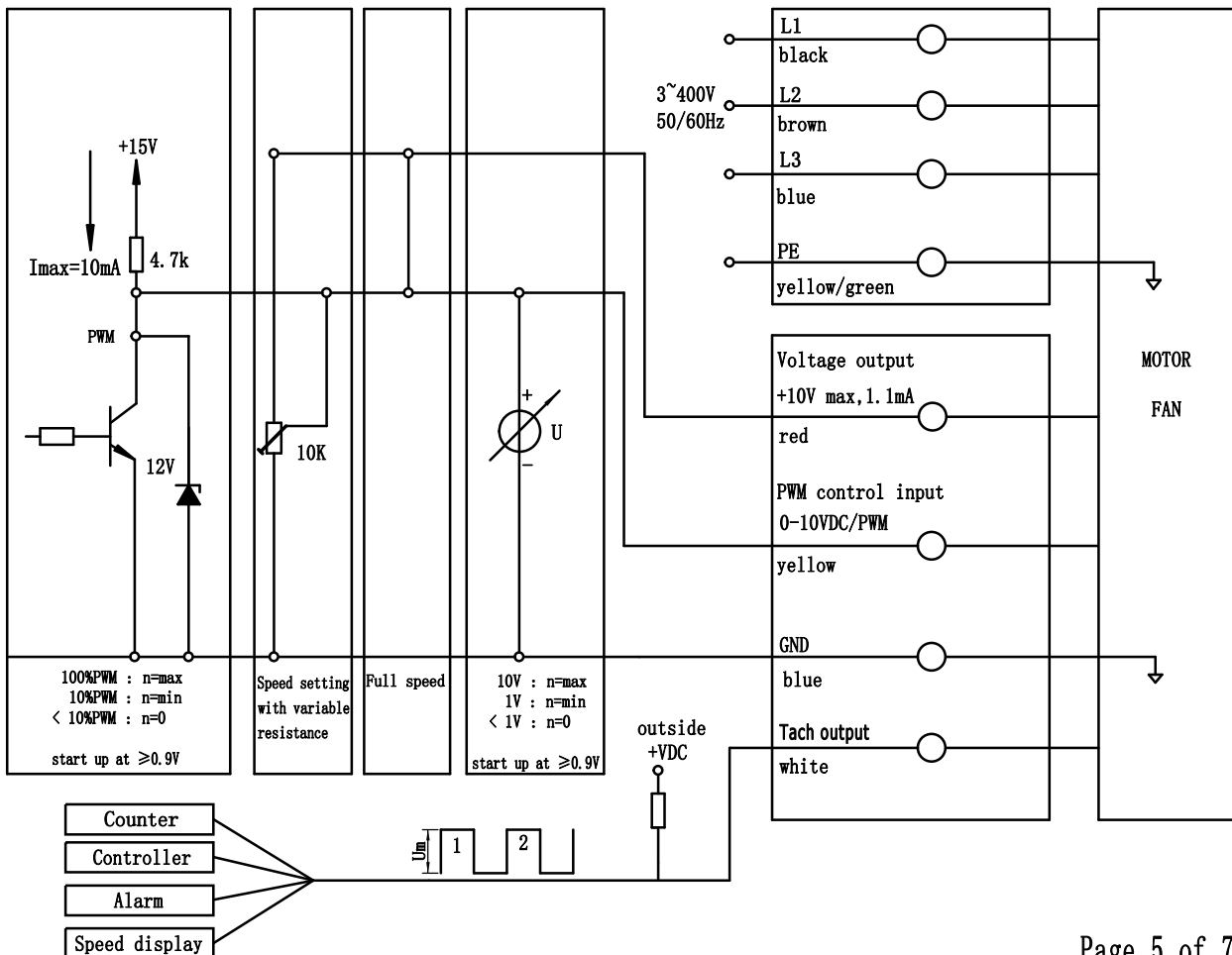

FANLAB

(3). FG signal connection diagram:

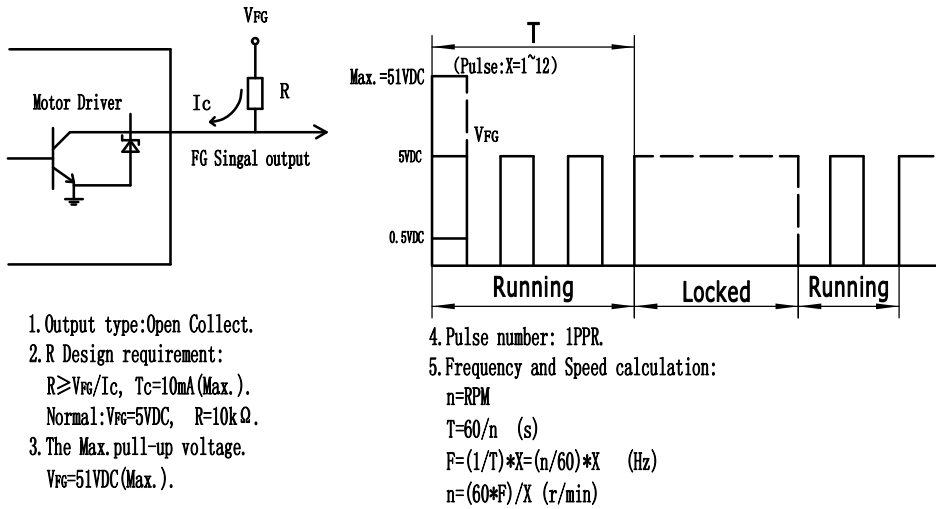

(4). Speed control signal diagram:

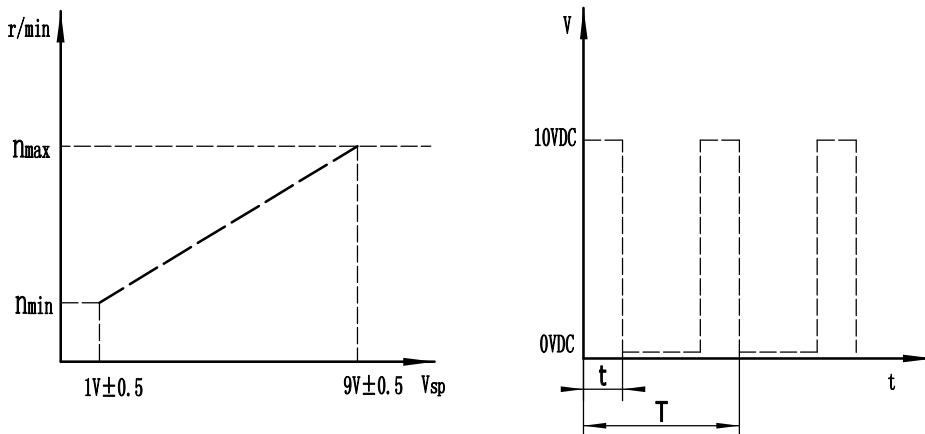

1. The speed control signal: 0~10VDC / PWM
2. At full speed, speed wire can be directly connected with 48VDC or 24VDC or 12VDC or 10VDC direct line.
3. PWM frequency 1~10kHz, duty cycle 0~100%. The speed control signal of support for 0.9~10VDC Analog voltage pulse with PWM compatible.

FANLAB

Precautions

- 1、 The fan can be operate after the yellow and green wire of the fan connecting the ground effective, High risk, to prevent grounding caused by electric shock or not affected operation.
- 2、 The red, black, white, yellow, green lines of the fan are not allowed to access the high voltage ac power supply, to prevent burn out the fan.
- 3、 Green line prohibits direct connection red + 10 VDC or external dc power supply voltage output line. You need to connect an external resistor when you want the Square wave speed signal output. Details see the connecting screen.
- 4、 Fan may need to wait for a few seconds after the power supply to start running, ban after electrify immediately touch wind turbines or touch under low speed wind turbines, to prevent personal injury.
- 5、 Please read carefully the "technical specification before use the product ".