

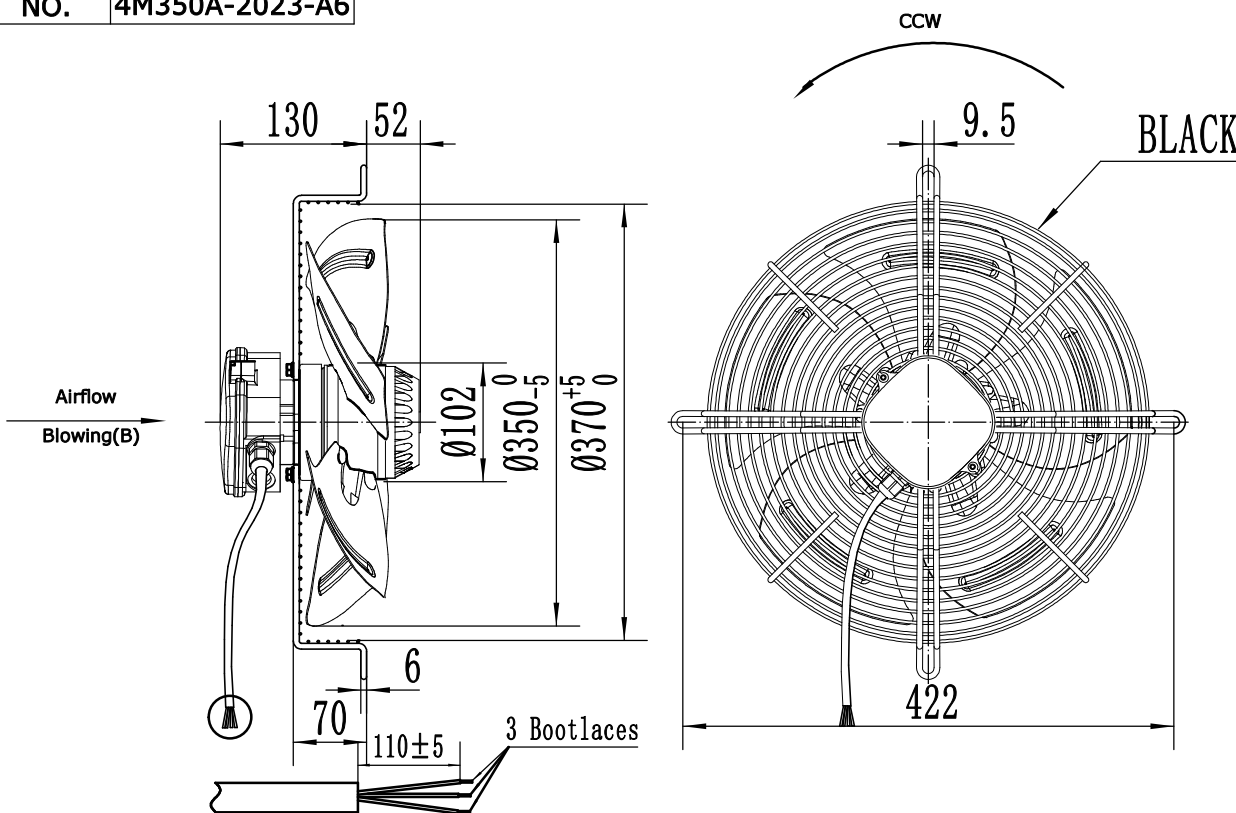

SPECIFICATION



UNIT	Axial fan motor
MOTOR	Single phase motor with capacitor
MOTOR TYPE	FL-4M350A230BOX-GCP-130
VOLTAGE (V)	230
FREQUENCY (Hz)	50/60
INPUT POWER (W)	170/240
CURRENT (A)	0.75/1.00
SPEED (r/min)	1420/1650
AIR FLOW 0Pa (m³/h)	2730/3168
NOISE (dBA)	65/67
CAPACITOR (µF/450V)	6(Square capacitor fixed with screw)
ROTATION	CCW ,looking into the end-shield
INSULATION CLASS	F
MOTOR PROTECTION	Thermocontact 150±5°C
TEMPERATURE RISE	75K max
TYPE OF PROTECTION	IP54
OPERATING TYPE	S1
AMBIENT TEMPERATURE	-40°C +60°C
BEARINGS	Ball bearings
MOUNTING TYPE	Horizontal or Vertical
ELECTRICAL CONNECTION	Lead wire RV-90 4G 0.50mm² ,Length 100mm in terminal box connected,Outer lead by THREE core PVC sheathed wire,Length 1300mm
APPROVALS	CE
NET WEIGHT/GROSS WEIGHT	6/7kg
PACKING	38.5*38.5*20cm
RINGS OF THE GRID WITH SAFE DISTANCE FOR THE FINGER 6 Vertical side -15 Horizontal side	

LABEL :



FLOW RATE CURVE:

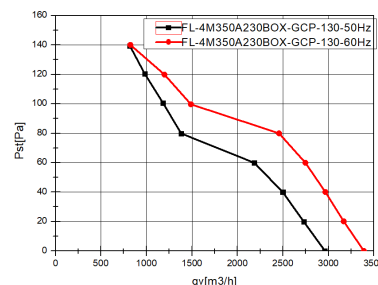

WIRING DIAGRAM:

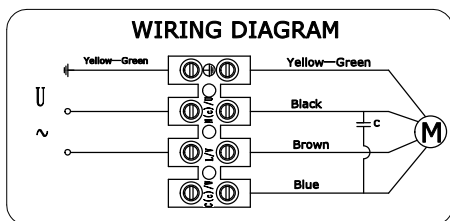

ErP2015 LABEL:

ErP2015 (N40)
N=40.8 η_{statA}= 29.13%
FL-4M350A230BOX-GCP-130

REV.	DESCRIPTION	APPROVED	DATE					SIGN	DATE	TITLE	FL-4M350A230BOX-GCP-130	
								DRN. BY		PROJECTION		
								CHD. BY				A4
								ENG. BY				SCALE
								APP. BY			SHEET: of	

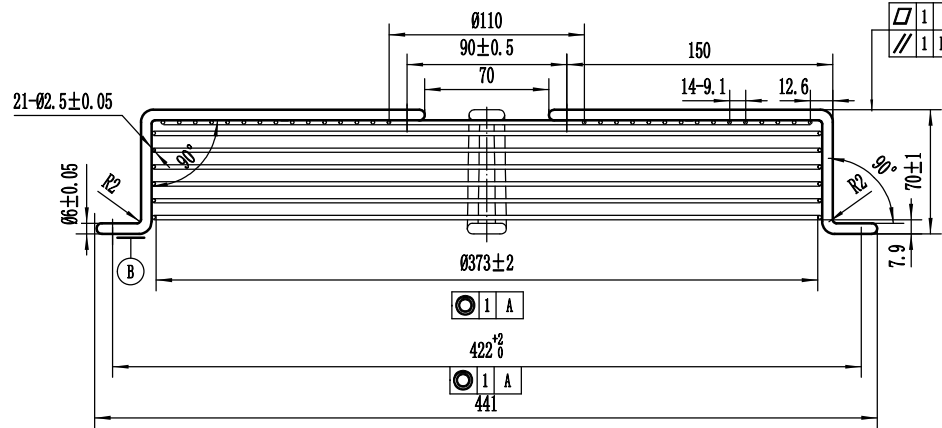

Install steel bars

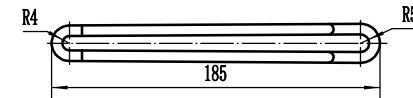
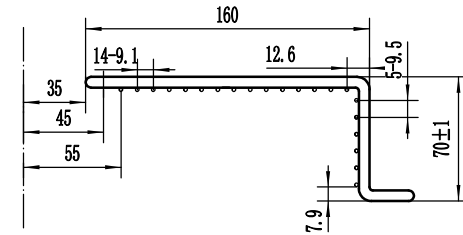

Auxiliary steel bars

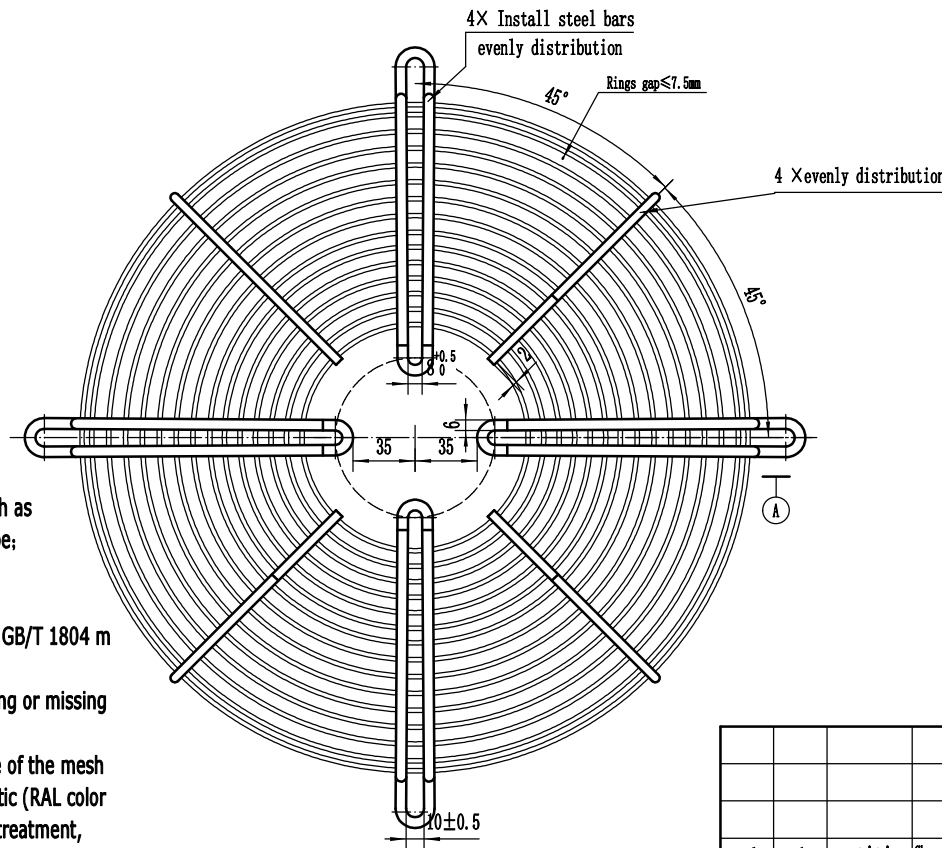
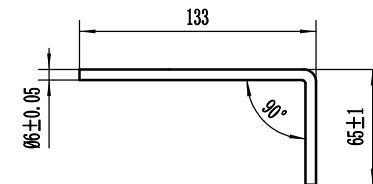

Technical requirement:

1. Rings are evenly arranged, without defects such as deformation, misalignment, and out of round shape;
2. Undeclared shape and position tolerance according to GB1184-L;
3. Undeclared dimensional tolerance according to GB/T 1804 m level;
4. The welding points are firm, flat, without missing or missing welds, and the sharp edges of the cuts are blunt;
5. Requirements for plastic powder on the surface of the mesh cover: Outdoor powder, surface sprayed with plastic (RAL color card 9005, black 65 degrees (60 degrees angle)) treatment, plastic layer uniform, smooth, without paint nodules, thickness 0.06-0.10mm, spray quality meets GB requirements, can pass 500h salt spray test;
6. Ensure that the rings gap meets the requirements, and the wire sizes in the figure are all bare rings sizes.

						Q195			
marks	number	partition	Change number	sign	year/month/date			350 flat grid H70	
design			standardization			weight		proportion	
revision			verify					1:3	
technology			ratify						
						PAGE 1/1		projection ticks VERSTON A/2	